



**PM/PB Series
Microprocessor Panel Meter
Operation Manual**



FineTek Co., Ltd.

No.16, Tzuchiang St., Tucheng Industrial Park, Taipei Hsien, Taiwan

Tel: 886-2-22696789 Fax: 886-2-22686682

e-mail: info@fine-tek.com <http://www.fine-tek.com>

PB-01 2007.05.22

2. Operation Panel / Technical Specification / & Installation Dimension

2.1 PB-1471

2.1.1 Operation Panel

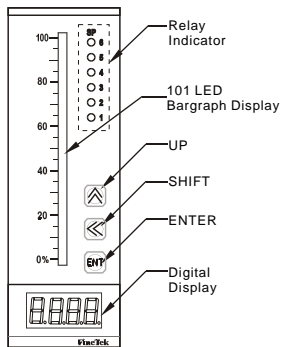

2.1.2 Technical Specifications

- Display**
 4 digits, 0.36" 7 segment red LED display.
 101 segment LED red bargraph display.
 Display range: -1999~+9999
- Input Signal**
 Range: 0~20mA, 4~20mA, 20~0mA, 20~4mA, 0~10V.
 (Refer to Ordering Information for more types)
- Accuracy: 0.1%FS or ± 1 digit
- ADC resolution: 4-1/2 digit
- Sampling Rate: 4 samples/second
- Relay Contact:
4 or 6 relays 3A 250VAC or 5A 30VDC (N.C. / N.O. jumper selectable)
- Working Condition :
0~50°C (20% to 90% RH non-condensed)
- Storage Condition:
0~70°C (20% to 90% RH non-condensed)
- Power Supply:
AC85V ~ AC265V Switching Power Supply
- Optional Output (Isolated):
 *Analog Output:
 0~20mA, 4~20mA, 20~0mA, 20~4mA
 0~10V, 2~10V, 0~5V, 1~5V.
 12 bit DAC resolution

2.1.3 Relay Outputs

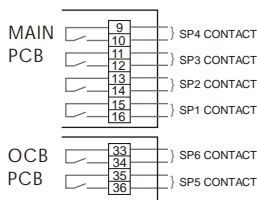

- All of relay original setting is N.O..
- To select N.C. / N.O. setting need from PC Board directly.
- The 4 sets N.C./N.O. jumper selector are near relay, which designis for user to select N.C./N.O. Type, the diagramis shown below :

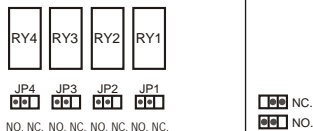

2.1.4 Exterior Dimensions

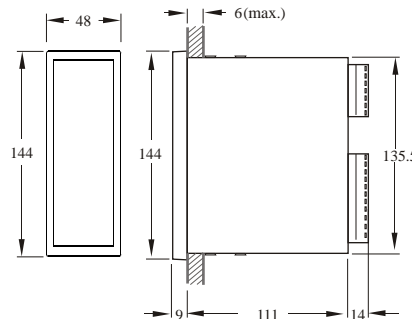

2.1.5 Cutout Dimensions

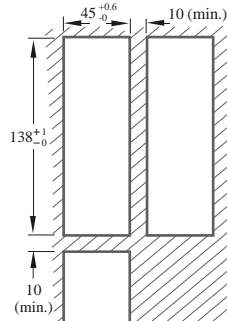

(unit : mm)

2.1.6 Terminal Arrangements

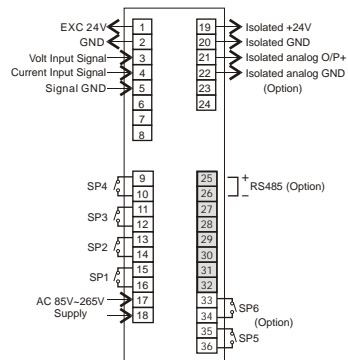

2.2 PB-1471 / PB-1570

2.2.1 Operation Panel

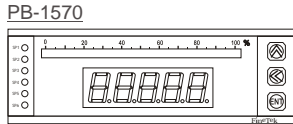
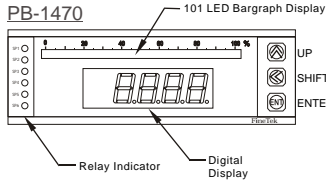

2.2.2 Technical Specifications

• Display

4 digits, 0.56" 7 segment red LED display.
101 segment LED red bargraph display.
Display range: -1999~+9999

(PB-1470 Series Products)

Display range: -19999~+32767

(PB-1570 Series Products)

• Input Signal

Range: 0~20mA, 4~20mA, 20~0mA, 20~4mA,
0~10V.

(Refer to Ordering Information for more types)

• Accuracy: 0.1%FS or ± 1 digit

• ADC resolution: 4-1/2 digit

• Sampling Rate: 4 samples/second

• Relay Contact: 4 or 6 relays, 3A 250VAC
or 5A 30VDC

(N.C./N.O. jumper selectable)

• Working Condition:

0~50°C (20% to 90% RH non-condensed)

• Storage Condition:

0~70°C (20% to 90% RH non-condensed)

• Power Supply:

AC85V ~ AC265V Switching Power Supply

Optional Output (Isolated) :

*Analog Output:

0~20mA, 4~20mA, 20~0mA, 20~4mA

0~10V, 2~10V, 0~5V, 1~5V.

12 bit DAC resolution.

2.2.3 Relay Outputs

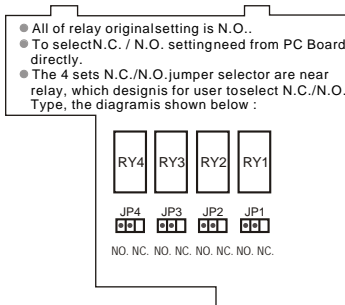
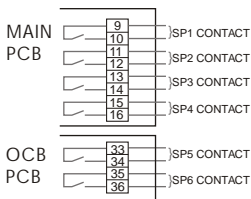

2.2.4 Exterior Dimensions

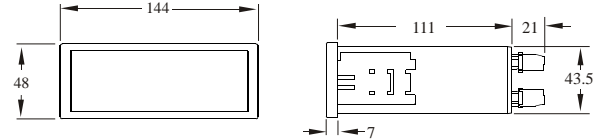

2.2.5 Cutout Dimensions

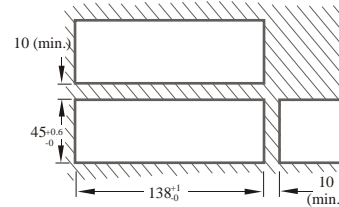

(unit : mm)

2.2.6 Terminal Arrangements

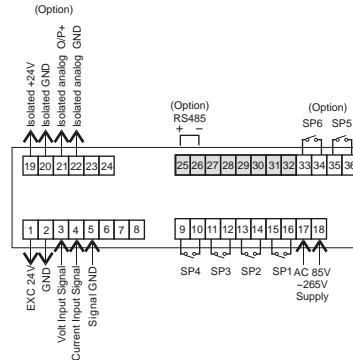

2.3.1 Operation Panel

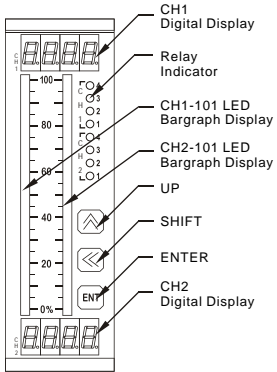

2.3.2 Technical Specifications

● **Display**
 Dual 4 digits, 0.36" 7 segment red LED display.
 Dual 101 segment LED red bargraph display.
 Display range: -1999~+9999
 CH1 in RED color, CH2 in GREEN color.

● **Input Signal**
 Range: 0~20mA, 4~20mA, 20~0mA, 20~4mA, 0~10V.
 (Refer to Ordering Information for more types)

● Accuracy: 0.1%FS or ± 1 digit
 ● ADC resolution: 4-1/2 digit
 ● Sampling Rate: 2 samples/second/channel
 ● Relay Contact:
 4 or 6 relays 3A, 250VAC or 5A30VDC (N.C. / N.O. jumper selectable)

● Working Condition :
 0~50°C (20% to 90% RH non-condensed)
 ● Storage Condition:
 0~70°C (20% to 90% RH non-condensed)
 ● Power Supply:
 AC85V ~ AC265V Switching Power Supply

Optional Output (Isolated):
 *Analog Output:
 0~20mA, 4~20mA, 20~0mA, 20~4mA
 0~10V, 2~10V, 0~5V, 1~5V.
 12 bit DAC resolution.

2.3.3 Relay Outputs

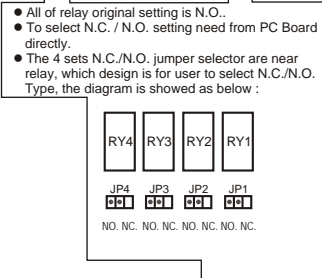
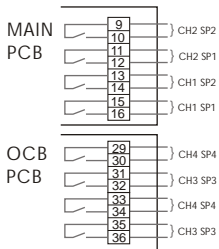

● All of relay original setting is N.O..
 ● To select N.C. / N.O. setting need from PC Board directly.
 ● The 4 sets N.C./N.O. jumper selector are near relay, which design is for user to select N.C./N.O. Type, the diagram is showed as below :

2.3.4 Exterior Dimensions

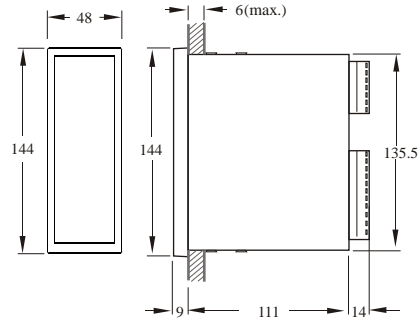

2.3.5 Cutout Dimensions

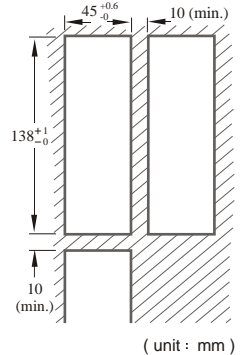

2.3.6 Terminal Arrangements

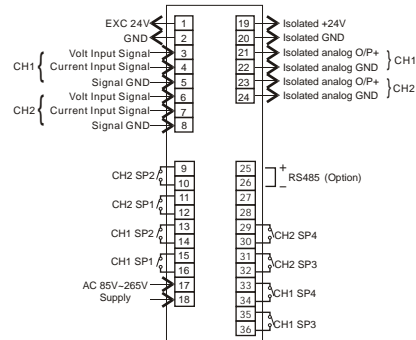

2.4.1 Operation Panel

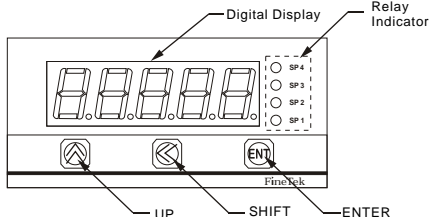

2.4.2 Technical Specifications

• Display

4 digits (PM-1430), 5digit (PM-1530)
 0.56" 7 segment red LED display.
 101 segment LED red bargraph display.
 Display range: -1999~+9999 (PM-1430)
 -19999~+32767 (PM-1530)

• Input Signal

Range: 0~20mA, 4~20mA, 20~0mA,
 20~4mA, 0~10V.
 (Refer to Ordering Information for more types)

- Accuracy: 0.1%FS or ± 1 digit
- ADC resolution: 4-1/2 digit
- Sampling Rate: 4 samples/second
- Relay Contact:
 4~6 relays, 3A 250VAC or 5A 30VDC
 (N.C./N.O. Jumper selectable)

- Working Condition: 0~50°C
 (20% to 90% RH non-condensed)
- Storage Condition: 0~70°C
 (20% to 90% RH non-condensed)
- Power Supply:
 AC85V ~ AC265V Switching
 Power Supply

Optional Output (Isolated):
 * Analog Output:
 0~20mA, 4~20mA, 20~0mA, 20~4mA
 0~10V, 2~10V, 0~5V, 1~5V.
 12 bit DAC resolution.

2.4.3 Relay Outputs

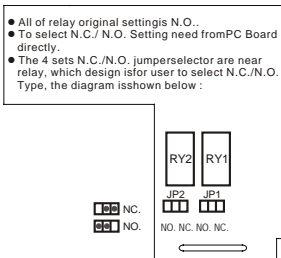
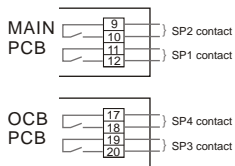

2.4.4 Exterior Dimensions

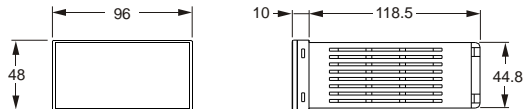

2.4.5 Cutout Dimensions

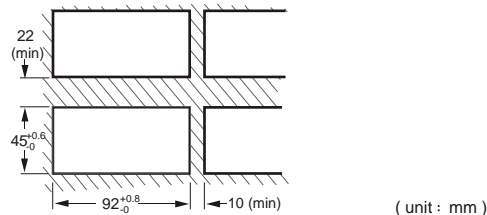

2.4.6 Terminal Arrangements

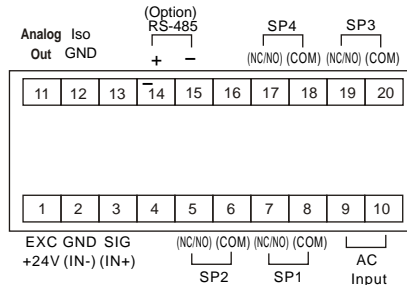

2.5.1 Operation Panel

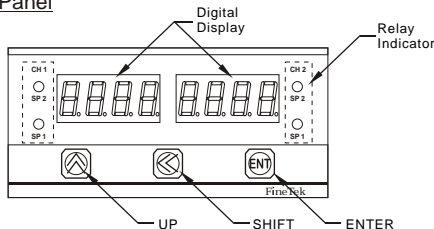

2.5.2 Technical Specifications

● Display

4 digits, 0.36" 7 segment red LED display.
Display range: -1999~+9999

● Input Signal

Range: 0~20mA, 4~20mA, 20~0mA, 20~4mA, 0~10V.
(Refer to Ordering Information for more types)

- Accuracy: 0.1%FS or ± 1 digit
- ADC resolution: 4-1/2 digit
- Sampling Rate: 4 samples/second
- Relay Contact: 4 or 6 relays, 3A 250VAC or 5A 30VDC (N.C./N.O. Jumper selectable)

- Working Condition: 0~50°C (20% to 90% RH non-condensed)
- Storage Condition: 0~70°C (20% to 90% RH non-condensed)
- Power Supply: AC85V ~ AC265V Switching Power Supply

Optional Output (Isolated) :

*Analog Output:
0~20mA, 4~20mA, 20~0mA, 20~4mA, 0~10V, 2~10V, 0~5V, 1~5V.
12 bit DAC resolution.

2.5.3 Relay Outputs

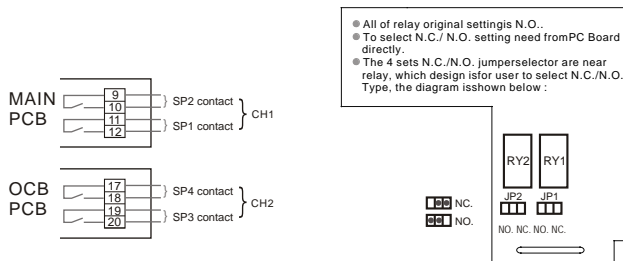

- All of relay original settings N.O..
- To select N.C./ N.O. setting need from PC Board directly.
- The 4 sets N.C./N.O. jumperselector are near relay, which design isfor user to select N.C./N.O. Type, the diagram isshown below :

2.5.4 Exterior Dimensions

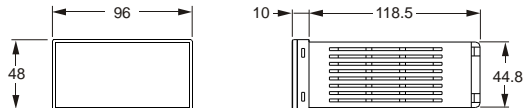

2.5.5 Cutout Dimensions

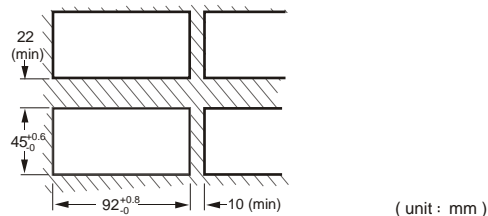

(unit : mm)

2.5.6 Terminal Arrangements

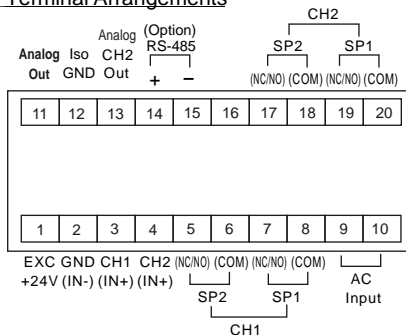

3. Program Settings

3.1 Program Settings Flowchart

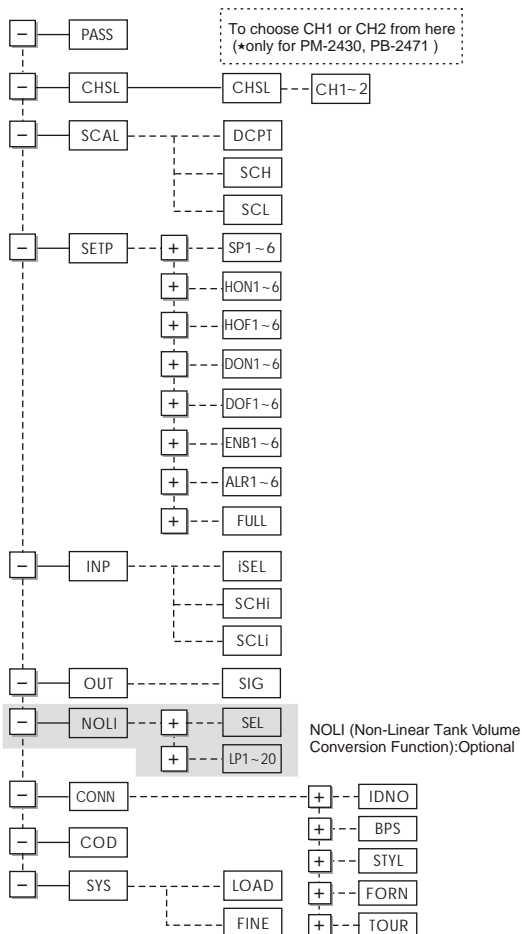

3.2 Input Buttons

Buttons Explanation

The settings on the panel meter is controlled by the 3 buttons on the panel, (UP, SHIFT and ENTER). First choose the function, then input required value of 3 buttons while in "Selection" and "Setting" are:

	Selection	Settings
UP	Escape	Addition
SHIFT	Enter	Position Shift
ENTER	Switch	Confirmation

ENTER Button

1) Main menu switch or sub-menu switch.

Example: STEP 1 ~ STEP 2 and STEP 3 ~ STEP 5.

2) Confirmation to save settings

Example: Confirmation of change of SCHi value

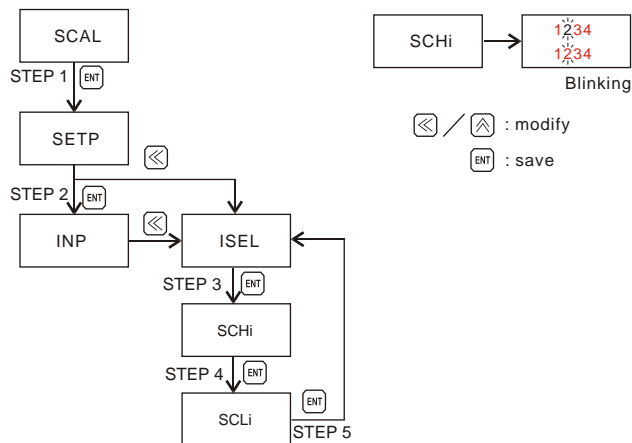

3.3 Input Signal Module and Setup Method

SIM Input Module Specifications and Jumper Elaboration.

Module	Input Signal	Range	Jumper Setting
01	4~20mA with Exc+24V	DC 4~20mA	
02	±0~20mA with Exc+24V	DC 0~20mA	
03	±0~200mA with Exc+24V	DC 0~200mA	
04	±5V with Exc+24V	DC ±5V	
05	±10 with Exc+24V	DC ±10V	
06	±20 with Exc+24V	DC ±20V	
07	±200V with Exc+24V	DC ±200V	
A1	2mA AC Scaled RMS	AC 0~2mA	Left & right Jumpers must change symmetrically.
A2	20mA AC Scaled RMS	AC 0~20mA	
A3	200mA AC Scaled RMS	AC 0~200mA	
A4	1A AC Scaled RMS	AC 0~1A	
A5	5A AC Scaled RMS	AC 0~5A	
B1	100mV AC Scaled RMS	DC 0~100mV	
B2	200mV AC Scaled RMS	AC 0~200mV	
B3	2V AC Scaled RMS	AC 0~2V	
B4	20V AC Scaled RMS	AC 0~20V	J3
B5	200V AC Scaled RMS	AC 0~200V	
B6	600V AC Scaled RMS	AC 0~600V	
C1	±2mA Exc+24V	DC ±2mA	Left & right Jumpers must change symmetrically.
C2	±20mA Exc+24V	DC ±20mA	
C3	±200mA Exc+24V	DC ±200mA	
C4	±1Amp	DC ±1A	
C5	±5 Amp	DC ±5A	
D1	±20mV Exc+24V	DC ±20mV	
D2	±50mV Exc+24V	DC ±50mV	
D3	±100mV Exc+24V	DC ±100mV	
D4	±200mV Exc+24V	DC ±200mV	

◀ SHIFT Button

- Entry into main menu or entry into sub-menu or position change.

Example: STEP 1, STEP 2 and STEP 3 ~ STEP 7

- Position shift

After entering into value input, use this button to shift between digit position.

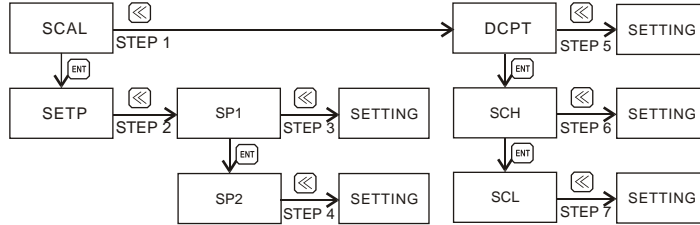

- Moving Numeric : Moving the parameter numeric to modify. For example : Into SCHi function setting, one of the numeric will blinking to modify, and use SHIFT bottom to select blinking digit for modify.

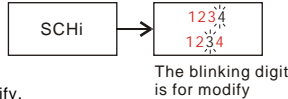

⬆ UP Button

- To escape from main menu and to escape from sub-menu to main menu. Example: STEP 1 and STEP 2

- To change input value by addition. Example: To change the value of SCHi from "1230" to "1234", press up button four times.

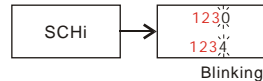
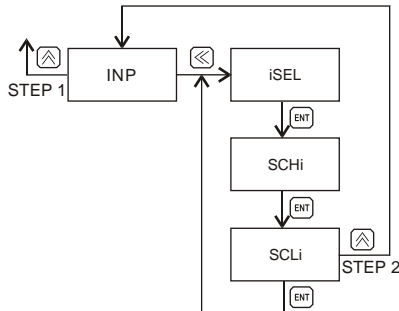

3.4 Program Commands List

Command	Description	4 Digit Setting Range	4 Digit Factory Default	5 Digit Setting Range	5 Digit Factory Default
PASS	Password	0~9999	4607	0~9999	4607
CHSL	Channel Selection	CH1/CH2	CH1	CH1/CH2	CH1
SCAL	Set DCPT, SCH, SCL				
DCPT	Decimal point Selection	0~3	Dot1	0~4	Dot2
SCH	Display value for SPAN	-1999~9999	100.0	-19999~32767	100.00
SCL	Display value for SPAN	-1999~9999	000.0	-19999~32767	000.00
SETP	Set SP1~6, HON1~6, DON1~6, DOF1~6, ENB1~6, ALR1~6, FULL				
SP1	SP1 Set point value	-1999~9999	020.0	-19999~32767	020.00
SP2	SP2 Set point value	-1999~9999	040.0	-19999~32767	040.00
SP3	SP3 Set point value	-1999~9999	060.0	-19999~32767	060.00
SP4	SP4 Set point value	-1999~9999	080.0	-19999~32767	080.00
SP5	SP5 Set point value	-1999~9999	NULL	-19999~32767	NULL
SP6	SP6 Set point value	-1999~9999	NULL	-19999~32767	NULL
HON1	SP1 Hysterises High Band	0~9999	000.0	0~32767	000.00
HON2	SP2 Hysterises High Band	0~9999	000.0	0~32767	000.00
HON3	SP3 Hysterises High Band	0~9999	000.0	0~32767	000.00
HON4	SP4 Hysterises High Band	0~9999	000.0	0~32767	000.00
HON5	SP5 Hysterises High Band	0~9999	000.0	0~32767	000.00
HON6	SP6 Hysterises High Band	0~9999	000.0	0~32767	000.00
HOF1	SP1 Hysterises Low Band	0~9999	000.0	0~32767	000.00
HOF2	SP2 Hysterises Low Band	0~9999	000.0	0~32767	000.00
HOF3	SP3 Hysterises Low Band	0~9999	000.0	0~32767	000.00
HOF4	SP4 Hysterises Low Band	0~9999	000.0	0~32767	000.00
HOF5	SP5 Hysterises Low Band	0~9999	000.0	0~32767	000.00
HOF6	SP6 Hysterises Low Band	0~9999	000.0	0~32767	000.00
DON 1	SP1 Delay On Setting	00~99	00	0~99	00
DON 2	SP2 Delay On Setting	00~99	00	0~99	00
DON 3	SP3 Delay On Setting	00~99	00	0~99	00
DON 4	SP4 Delay On Setting	00~99	00	0~99	00
DON 5	SP5 Delay On Setting	00~99	00	0~99	00
DON 6	SP6 Delay On Setting	00~99	00	0~99	00

Command	Description	4 Digit Setting Range	4 Digit Factory Default	5 Digit Setting Range	5 Digit Factory Default
DOF1	SP1 Delay Off Setting	00~99	00	0~999	000
DOF2	SP2 Delay Off Setting	00~99	00	0~999	000
DOF3	SP3 Delay Off Setting	00~99	00	0~999	000
DOF4	SP4 Delay Off Setting	00~99	00	0~999	000
DOF5	SP5 Delay Off Setting	00~99	00	0~999	000
DOF6	SP6 Delay Off Setting	00~99	00	0~999	000
ENB1	SP1 Relay On / Off Selecting	ON / OFF	ON	ON / OFF	ON
ENB2	SP2 Relay On / Off Selecting	ON / OFF	ON	ON / OFF	ON
ENB3	SP3 Relay On / Off Selecting	ON / OFF	ON	ON / OFF	ON
ENB4	SP4 Relay On / Off Selecting	ON / OFF	ON	ON / OFF	ON
ENB5	SP5 Relay On / Off Selecting	ON / OFF	OFF	ON / OFF	OFF
ENB6	SP6 Relay On / Off Selecting	ON / OFF	OFF	ON / OFF	OFF
ALR1	SP1 Hi / Lo Alarm Selection	HI / LO	LO	HI / LO	LO
ALR2	SP2 Hi / Lo Alarm Selection	HI / LO	LO	HI / LO	LO
ALR3	SP3 Hi / Lo Alarm Selection	HI / LO	HI	HI / LO	HI
ALR4	SP4 Hi / Lo Alarm Selection	HI / LO	HI	HI / LO	HI
ALR5	SP5 Hi / Lo Alarm Selection	HI / LO	HI	HI / LO	HI
ALR6	SP6 Hi / Lo Alarm Selection	HI / LO	HI	HI / LO	HI
FULL	Enter this item for all setting items	YES / NO	NO	YES / NO	NO
inp	Input Signal Setting				
iSEL	Output Type Selection		4~20		4~20
SCHi	SPAN Percentage for SPE mode	-1999~9999	100.0	-19999~32767	100.00
SCLi	ZERO Percentage for SPE mode	-1999~9999	000.0	-19999~32767	000.00
out	Output Signal Setting				
SIG	Analog Output Type Selection		4~20		4~20
NOLI	Non-Linear Tank Function				
SEL	Enable / Disable		ON / OFF	OFF	ON / OFF
LP1	Control Point #1	0~1999	5	0~19999	5
LP2	Control Point #2	0~1999	10	0~19999	10
LP3	Control Point #3	0~1999	15	0~19999	15

Command	Description	4 Digit Setting Range	4 Digit Factory Default	5 Digit Setting Range	5 Digit Factory Default
LP4	Control Point #4	0~1999	20	0~19999	20
LP5	Control Point #5	0~1999	25	0~19999	25
LP6	Control Point #6	0~1999	30	0~19999	30
LP7	Control Point #7	0~1999	35	0~19999	35
LP8	Control Point #8	0~1999	40	0~19999	40
LP9	Control Point #9	0~1999	45	0~19999	45
LP10	Control Point #10	0~1999	50	0~19999	50
LP11	Control Point #11	0~1999	55	0~19999	55
LP12	Control Point #12	0~1999	60	0~19999	60
LP13	Control Point #13	0~1999	65	0~19999	65
LP14	Control Point #14	0~1999	70	0~19999	70
LP15	Control Point #15	0~1999	75	0~19999	75
LP16	Control Point #16	0~1999	80	0~19999	80
LP17	Control Point #17	0~1999	85	0~19999	85
LP18	Control Point #18	0~1999	90	0~19999	90
LP19	Control Point #19	0~1999	95	0~19999	95
LP20	Control Point #20	0~1999	100	0~19999	100
cod	Change Password	0~9999	4607	4607	0~9999
SYS	System Settings				
LOAD	Reset to factory default	YES/NO	NO	YES/NO	NO
FINE	Read Software Version Code				

Command	Description	Setting Range	Factory Default
CONN	RS485 Settings		
IDNO	Settings ModBus Address	0~255	255
BPS	Setting ModBus BaudRate	more	600
600	600BPS	600	
1200	1200BPS	1200	
2400	2400BPS	2400	
4800	4800BPS	4800	
9600	9600BPS	9600	
144G	14400BPS	14400	
192G	19200BPS	19200	
288G	28800BPS	28800	
576G	57600BPS	57600	
STYL	Settings Data Type	more	8N1
8N1	8 Byte, No Parity, 1 Stop Bits	8N1	
7N2	7 Byte, No Parity, 2 Stop Bits	7N2	
7O1	7 Byte, Odd Parity, 1 Stop Bits	7O1	
7E1	7 Byte, Even Parity, 1 Stop Bits	7E1	
8N2	8 Byte, No Parity, 2 Stop Bits	8N2	
8O1	8 Byte, Odd Parity, 1 Stop Bits	8O1	
8E1	8 Byte, Even Parity, 1 Stop Bits	8E1	
7O2	7 Byte, Odd Parity, 2 Stop Bits	7O2	
7E2	7 Byte, Even Parity, 2 Stop Bits	7E2	
FORN	Settings Data Format	more	HEX
HEX	RTU Mode	HEX	
ASCI	ASCII Mode	ASCII	
TOUT	Time Out	100~9999mS	

3.5 Input Signal Settings

This section will elaborate how to adapt to different input signals in the panel meter, by using the correct jumper and using iSEL command. Panel meter series can accommodate 6 types of conventional input signals, 20mA, 200mA, 5V, 10V, 20V, 200V, please refer below for setup.

STEP 1: Please confirm the type of input signal

STEP 2: Open up MG casing and locate the SIM input signal module, select the jumper connection that corresponds to the required input signal.

STEP 3: Enter the main menu of the MG after password input, select iSEL and select the correct input signal from the list below.

3.5.1 Diagram

48x96

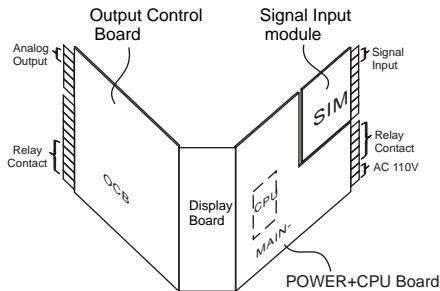

48x144

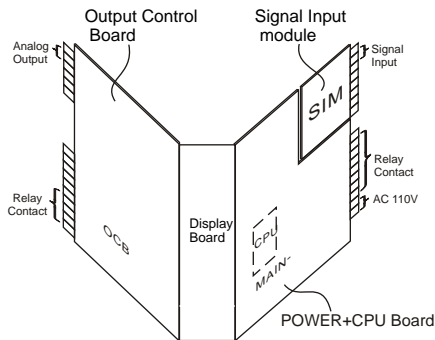

3.5.2 Input Signal & Setting Table

SIM No.	Signal Type	Jumper position	User Setup (iSEL)
01 & 02	0~20mA	20mA	iSEL → 0 - 20
	4~20mA		iSEL → 4 - 20
	20~0mA		iSEL → 20 - 0
	20~4mA		iSEL → 20 - 0
	Special range 0~20mA		iSEL → SPE → SCHi SCLi
03	A200mA Special range 0~200mA	200mA	iSEL → 0 - 20 iSEL → SPE → SCHi SCLi Refer to 4.2.2
04	A5V 1~5V Special range 0~5V	5V	iSEL → 0 - 5 iSEL → 1 - 5 iSEL → SPE → SCHi SCLi Refer to 4.2.2
05	A10V 2~10V Special range 0~10V	10V	iSEL → 0 - 10 iSEL → 2 - 10 iSEL → SPE → SCHi SCLi Refer to 4.2.2
06	A20V Special range 0~20V	20V	iSEL → 0 - 20 iSEL → SPE → SCHi SCLi Refer to 4.2.2
07	A200V Special range 0~200V	200V	iSEL → 0 - 20 iSEL → SPE → SCHi SCLi Refer to 4.2.2
A1	AC Current RMS 0~2mA	2mA	iSEL → 0 - 10 SCAL → DCPT → 3 → SCH → 2.000
A2	AC Current RMS 0~20mA	20mA	iSEL → 0 - 10 SCAL → DCPT → 2 → SCH → 20.00

SIM No.	Signal Type	Jumper position	User Setup (iSEL)
A3	AC Current RMS 0~200mA	200mA	iSEL → 0 - 10
			SCAL → DCPT → 1
			SCH → 200.0
A4	AC Current RMS 0~1A	1A	iSEL → 0 - 10
			SCAL → DCPT → 3
			SCH → 100.0
A5	AC Current RMS 0~5A	5A	iSEL → 0 - 10
			SCAL → DCPT → 3
			SCH → 5.000
B1	AC Voltage RMS 0~100mV	100mV	iSEL → 0 - 10
			SCAL → DCPT → 1
			SCH → 100.0
B2	AC Voltage RMS 0~200mV	200mV	iSEL → 0 - 10
			SCAL → DCPT → 1
			SCH → 200.0
B3	AC Voltage RMS 0~2V	2V	iSEL → 0 - 10
			SCAL → DCPT → 3
			SCH → 2.000
B4	AC Voltage RMS 0~20V	20V	iSEL → 0 - 10
			SCAL → DCPT → 2
			SCH → 20.00
B5	AC Voltage RMS 0~200V	200V	iSEL → 0 - 10
			SCAL → DCPT → 1
			SCH → 200.0
B6	AC Voltage RMS 0~600V	600V	iSEL → 0 - 10
			SCAL → DCPT → 1
			SCH → 600.0

Refer to
4.2.2

Refer to
4.2.2

SIM No.	Signal Type	Jumper position	User Setup (iSEL)
C1	DC Current A2mA	2mA	iSEL → 0 - 10
			SCAL → DCPT → 3
			SCH → 2.000
C2	DC Current A20mA	20mA	iSEL → 0 - 10
			SCAL → DCPT → 2
			SCH → 20.00
C3	DC Current A200mA	200mA	iSEL → 0 - 10
			SCAL → DCPT → 1
			SCH → 200.0
C4	DC Current A1A	1A	iSEL → 0 - 10
			SCAL → DCPT → 3
			SCH → 1.000
C5	DC Current A5A	5A	iSEL → 0 - 10
			SCAL → DCPT → 3
			SCH → 5.000
D1	DC Voltage A20mV	20mV	iSEL → 0 - 10
			SCAL → DCPT → 2
			SCH → 20.00
D2	DC Voltage A50mV	50mV	iSEL → 0 - 10
			SCAL → DCPT → 1
			SCH → 050.0
D3	DC Voltage A100mV	100mV	iSEL → 0 - 10
			SCAL → DCPT → 1
			SCH → 100.0
D4	DC Voltage A200mV	200mV	iSEL → 0 - 10
			SCAL → DCPT → 1
			SCH → 200.0

3.5.3 Current Signal Input Example

A. 2 wire 4-20mA current signal input example

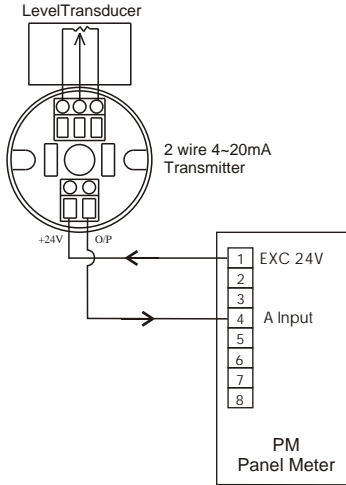

B. 3 wire 4-20mA current signal input example

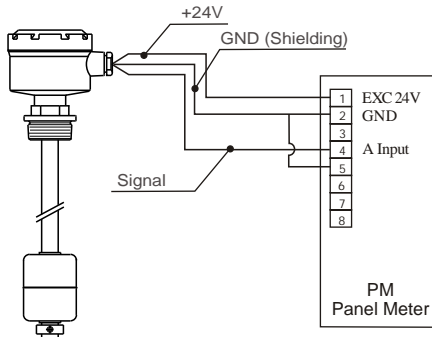

3.5.4 Non-linear feature settings

Special feature:

Non-linear settings could be used in applications concerning non-conventional shaped tanks, thereby solving the problem for level v.s. volume measurement for non-linear tank shapes.

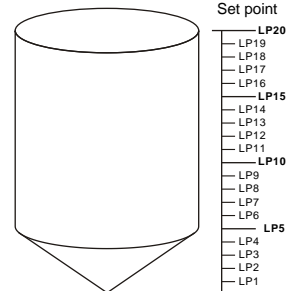
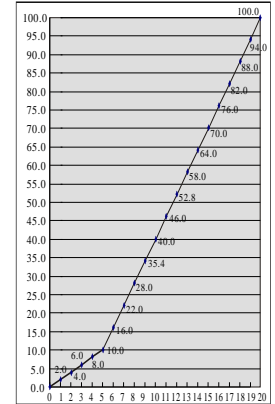
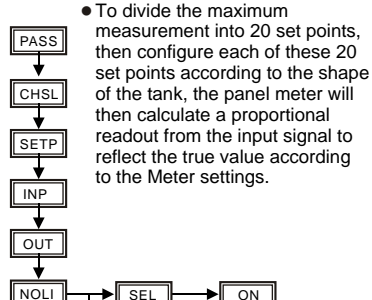

|||||| 3.6 Output Signal Setting ||||||

3.6.1 Optional relay output setting

The optional relay output is switchable to NO (Normal Open) or NC (Normal Close), it is selectable by the jumper on the OCB (Output Control Board). The default setting is "NO".

- Model: PB-1470, PB-1471, PB-1570
SP5 and SP6 relay setting is as below drawing:

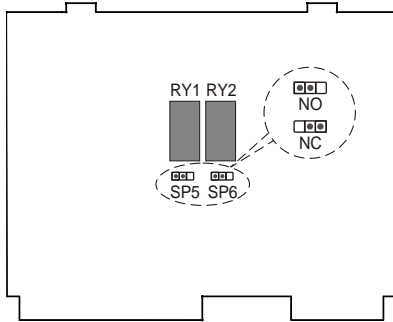

- Model: PB-2471 Series
SP5, SP6, SP7 and SP8 relay setting is as below drawing:

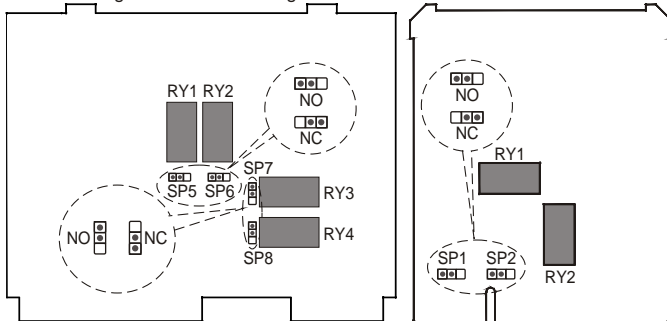

3.6.2 Analog output signal selection

Analog output signal (optional) provides 4~20mA or 0~10V signal, it can be selected by the jumper on the OCB (Output Control Board) for current output 4~20mA or voltage output (0~10V).

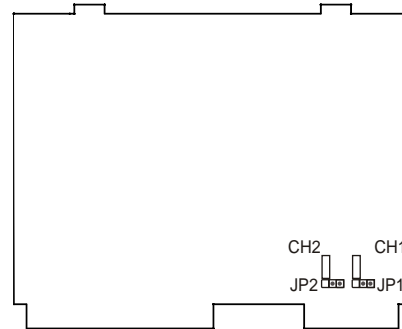

- Model: PB-1470, PB-1471, PB-1570, PB-2471

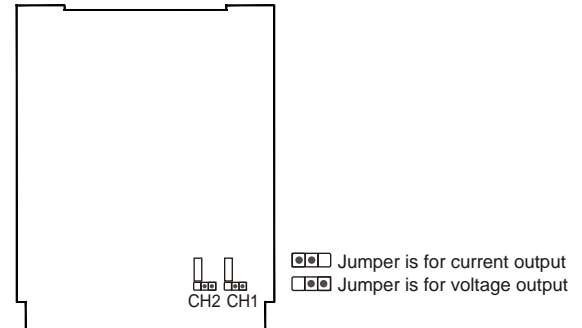

- Channel 1 is selected by JP1
- Channel 2 is selected by JP2
-  Jumper is for current output
-  Jumper is for voltage output

- Model: PM-1430, PM-1530, PM-2430



-  Jumper is for current output
-  Jumper is for voltage output

4. Program Setting Example

4.1 Diagram of Setting Values

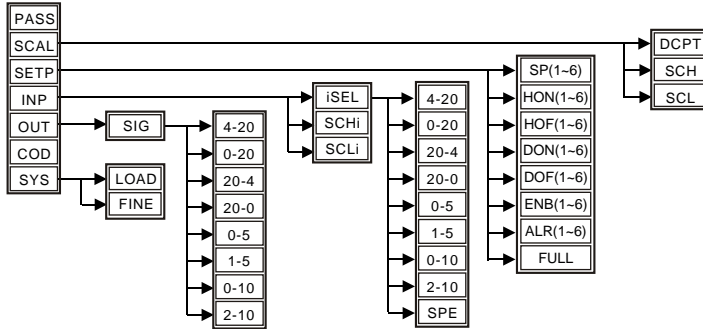

4.2 Program Settings Example

Magnetic Float Level Indicator delivers a current output that change proportionately with level. The 4 - 20mA output could be used in conjunction with the PB-1471 panel meter.

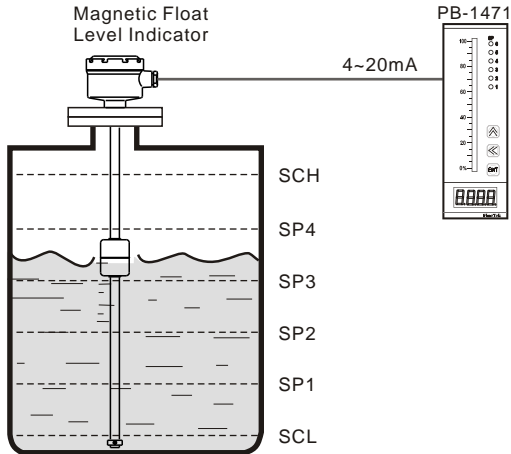

4.2.1 Example 1

Application example:

4mA represents 000.0 when the tank is empty
 20mA represents 100.0 when tank is full
 Set point 1 is set at 20% of full tank as low level alarm
 Set point 2 is set at 40% of full tank as low level alarm
 Set point 3 is set at 60% of full tank as high level alarm
 Set point 4 is set at 80% of full tank as high level alarm
 Linear proportional out signal
 Proportional output: Empty tank: 0mA, Full tank: 20mA

Settings are as follows:

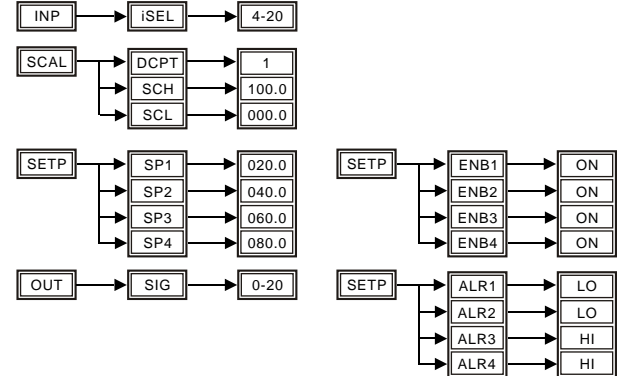

4.2.2 Example 2 (Special input signal range's proportional settings)

To address the problem of special input signal range that falls within 4~20mA, use of the command "SPE" is needed to program a proportionate setting for the input.

Example is Fine Automation capacitance level indicator,
 Current Input range is 7mA ~ 11mA, to display 000.0% ~ 100.0%

Formula:

$$\frac{\text{SCHi} / \text{SCLi}}{\text{SPE}} \times 100\%$$

Settings are as follow:

Input current 7mA ~ 11mA

$\frac{7}{20} \times 100\% = 35\%$ $\frac{11}{20} \times 100\% = 55\%$

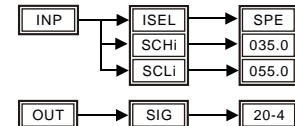

5. Frequently Asked Questions & Troubleshooting

4.2.3 Example 3

Value Settings are as follows:

SCH=100.0 SCL=000.0 SP1=020.0 HON1=005.0 HOF1=010.0
 DON=03 DOF=02 ENB1=ON ALR1=HI

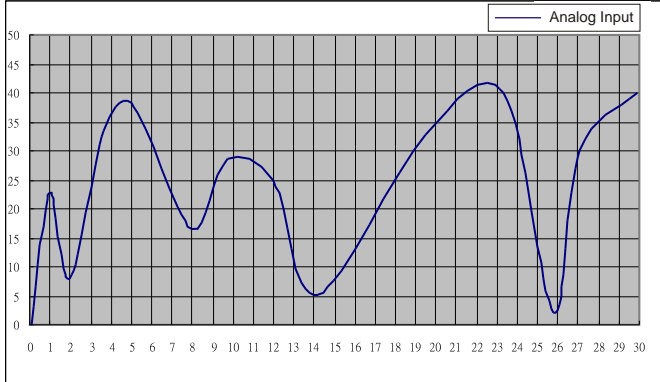

Set point 1's action diagram:

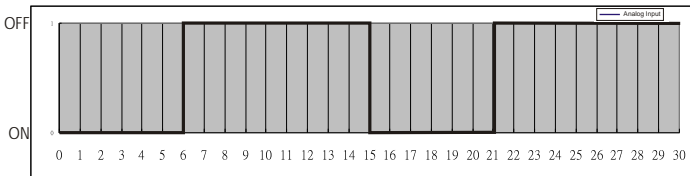

Problem	Rectification method
Panel Face doesn't lights up	<ol style="list-style-type: none"> 1) Check powersupply wire is it connected wrongly or not connected. 2) Check whether the power supply is AC85V ~ 265V.
Relay Contact fails to action	<ol style="list-style-type: none"> 1) Check whether LED indication on the panel face is doing action. 2. Check whether wiring on the terminals are connected correctly.
Panel face LED indicators and Relay contacts no action or not working properly.	<ol style="list-style-type: none"> 1) Enter operation menu, check "Enb1~E" is ON (Default is ON) 2) Enter operation menu, check "don1~don5", "daf1~daf5" has any set value. 3) Enter operation menu, check "Hon1~Hon5", "Hof1~Hof5" has any set value 4) Enter operation menu, check whether "RLt1~RLt5" has the same value as factory default.
Proportional signal input does not correspond to panel display	Enter operation menu, check "SCH", "SCL", "SEL", "SCH", & "SCL", is configured correctly.
No change in display and bargraph after proportionate input signal.	Check input signal connection is connected correctly or is it loose.